

LUCKBOIL

Drink Easily
Enjoy Your Life

LUCKBOIL

REVERSE OSMOSIS SYSTEM INSTALLATION AND MAINTENANCE HANDBOOK

Please read through this handbook in detail
before using and keep it for your reference.

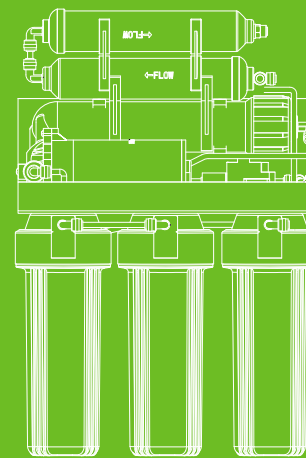

Hanging plate type

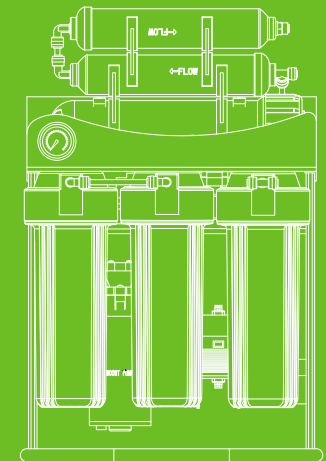

Bracket type

Specification of equipment:

- 75G
- 100G
- 200G
- 300G
- 400G

Operating mode:

- Manual
- 18S
- Automatic

CATALOGUE

Something for our respectable clients

1.Function characteristic	***** 1
2.Operation principle & technical process	*** 2-10
3.Main technical parameter	***** 10
4.Installation	***** 11-16
5.Operational approach	***** 16-17
6.Maintenance	***** 18-19
7.Warning	***** 19
8.Trouble shooting	***** 20-21
9.Packing list	***** 21

Something to respectable clients

To our respectable clients :

Thank you for your purchase of Reverse Osmosis Water Purifier System .

Now you own an advanced reverse osmosis water treatment equipment which is the pioneer of the world water treatment industry. The reverse osmosis water purifier system (RO system)can make the pure water, which is suitable for drinking directly.;to ensure your drinking water clean and be good for your health.

Before the installation, please read all the instructions of the installation and maintenance handbook in detail. Your installation must follow our instructions . Our instructions can bring a eligible and normative installation .With proper maintenance, your RO system will make high quality and tasty drinking water for many years

1.FUNCTION CHARACTERISTIC

- ◆ Using imported famous brand reverse osmosis membrane(RO Membrane),the RO system apply the most advanced reverse osmosis water treatment technology in the world currently to make ready-to-drink purified water. The RO system can eliminate foreign particles、colloid、organic substance、heavy metal、soluble solid、bacteria、virus、pyrogen and other harmful impurities from raw water, and only retain water molecule and dissolved oxygen, more than 96% of above substance will be removed.
- ◆ Using imported famous brand high pressure pump with good performances such as low noise, low vibration ,long service life and reliable quality.
- ◆ Pre treating cartridge can be replaced, with great effect, convenient replacement, economical cartridge, low operating cost.
- ◆ With the function of high pressure washing reverse osmosis membrane,it can extend the service life of RO Membrane effectively.
- ◆ Automatic-control of the purification process. When raw water stops supplying ,the machine stops automatically; When water storage tank reaches the capacity,the machine will also stop automatically.

2. WORKING PRINCIPLE AND PROCESS FLOW

2.1 Working principle:

RO system adopts American high-tech reverse osmosis technology. The automatic filter system is composed of five stage filter water purifier equipment. First, the raw water is filtered through three pre-filters.

- ◆ The first stage: PPF filter cartridge, remove up to 5 microns of suspended matter and other substances in raw water;
- ◆ The second stage: granular activated carbon cylinder;
- ◆ The third stage: high-density activated carbon filter cartridges to remove odors, chlorine and by-products from raw water.

After the above three stages of filtration, the filtered water is pushed by a high-pressure pump into the fourth stage: reverse osmosis (RO) membrane. Since the aperture of the reverse osmosis membrane is only 0.0001 micron, bacteria and filter viruses can only be reduced by 4000 times and filter viruses by more than 200 times to pass through the reverse osmosis membrane.

As a result, any ultra-fine impurities, harmful soluble solids, bacteria and viruses in the water are blocked by the high-density reverse osmosis membrane. Reverse osmosis membranes can separate other impurities and contaminants from filtered water. Harmful substances are automatically discharged from waste water outlets. The water filtered through the reverse osmosis membrane enters the pressure tank for storage. When the user opens the pure water faucet, the pure water will be filtered through the fifth level antibacterial activated carbon.

The system automatically controls the water purification process. When the raw water pressure is low or the storage tank is full, the system will automatically stop the purifier; When the water pressure returns to the normal state, the purifier will automatically restart operation. The water

purified by reverse osmosis system is bacteria-free, non-impurity living water, rich in oxygen, delicious taste, with excellent permeability and dissolution force, with the activation of human cells and viscera, enhance the function of disease resistance and immunity.

2.2 Technical Process

RO system for obtaining pure water: Inlet T and ball valve 1/2 "x 1/2" x 1/4"(quick connector) →PP filter cartridge→ probe raw water pressure switch→granular carbon filter cartridge→block carbon filter cartridge →inlet solenoid valve →booster pump→(bracket type with pressure gauge) display working pressure→RO membrane shell→check valve→ Detection high pressure switch→Water tank →coconut carbon filter cartridge(or more filter cartridges)→Water filter faucet

Waste water pipeline:
reverse osmosis membrane filter waste water outlet→waste water proportion or waste water solenoid valve →waste water collection box/floor drain

2.3 Reverse osmosis system layout and components/parts list

➤ Hanging plate type

◆ MANUAL TYPE

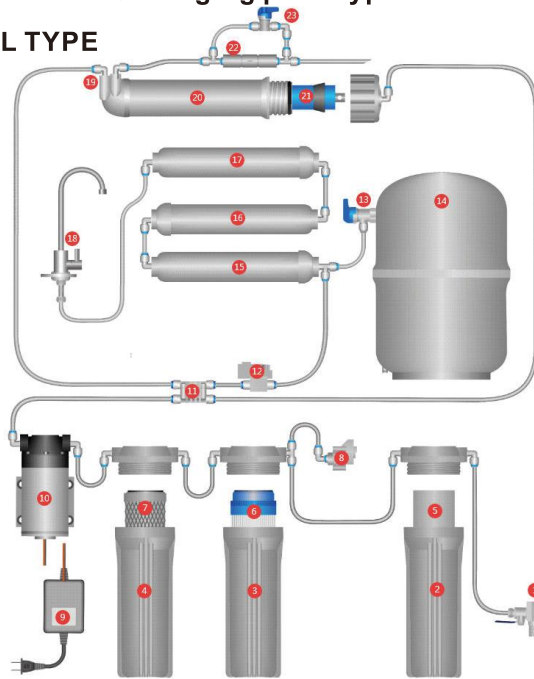

NO:	Product name	NO:	Product name
1	Inlet T and ball valve 1/4"or3/8"	13	Switch of water storage tank
2	First stage filter bottle	14	water storage tank
3	Secondary filter	15	Coconut carbon filter cartridge
4	Tertiary filtration	16	Mineral filter cartridge
5	PP filter cartridge	17	Alkaline filter cartridge
6	Granular activated carbon filter element	18	Water filter faucet
7	Compressed activated carbon filter	19	check valve
8	low pressure controller	20	Ro membrane housing
9	power adapter	21	Reverse osmosis filter element
10	booster pump	22	Drain water proportioner
11	four-way valve	23	Flush control valve
12	high pressure controller		

◆ 18S MODE

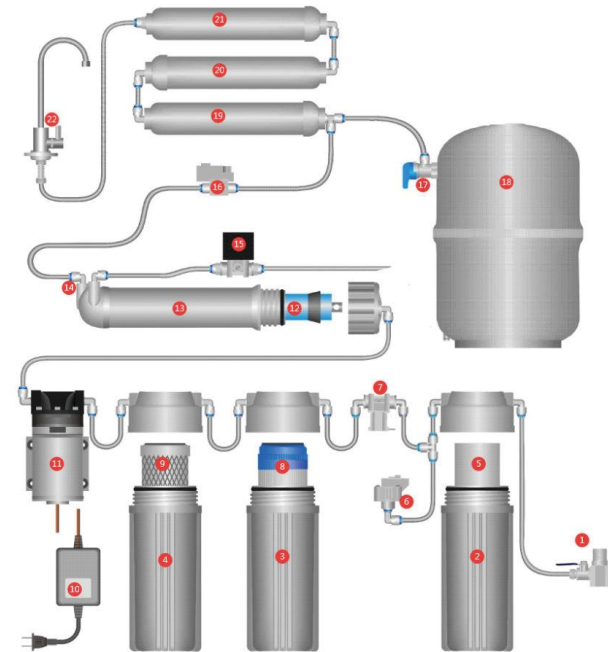

NO:	Product name	NO:	Product name
1	Inlet T and ball valve 1/4"or3/8"	12	Reverse osmosis filter element
2	First stage filter bottle	13	Ro membrane housing
3	Secondary filter	14	check valve
4	Tertiary filtration	15	Discharge water controller -18s
5	PP filter cartridge	16	high pressure controller
6	low pressure controller	17	Switch of water storage tank
7	water inlet solenoid valve	18	water storage tank
8	Granular activated carbon filter element	19	Mineral filter cartridge
9	Compressed activated carbon filter	20	Alkaline filter cartridge
10	power adapter	21	Water filter faucet
11	booster pump	22	Water filter faucet

◆ AUTOMATIC MODE

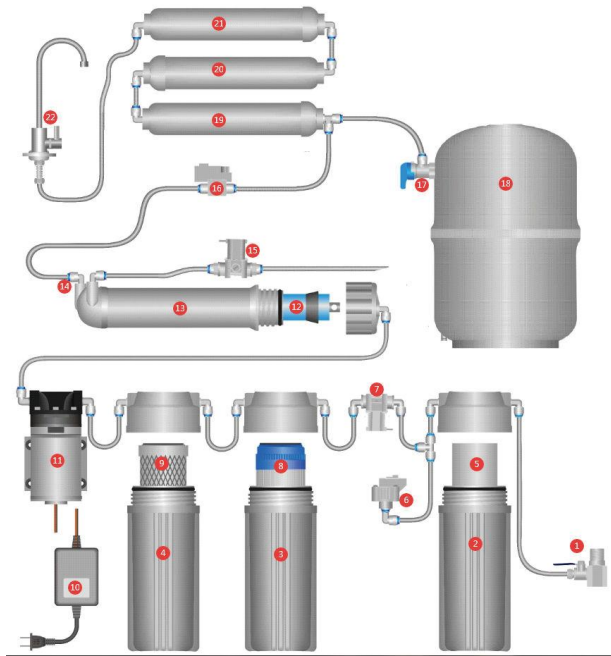

NO:	Product name	NO:	Product name
1	Inlet T and ball valve 1/4"or3/8"	12	Reverse osmosis filter element
2	First stage filter bottle	13	Ro membrane housing
3	Secondary filter	14	check valve
4	Tertiary filtration	15	Discharge water controller
5	PP filter cartridge	16	high pressure controller
6	low pressure controller	17	Switch of water storage tank
7	water inlet solenoid valve	18	water storage tank
8	Granular activated carbon filter element	19	Mineral filter cartridge
9	Compressed activated carbon filter	20	Alkaline filter cartridge
10	power adapter	21	Water filter faucet
11	booster pump	22	Water filter faucet

2.4 Reverse osmosis system layout and components/parts list

> Bracket type

◆ MANULAL TYPE

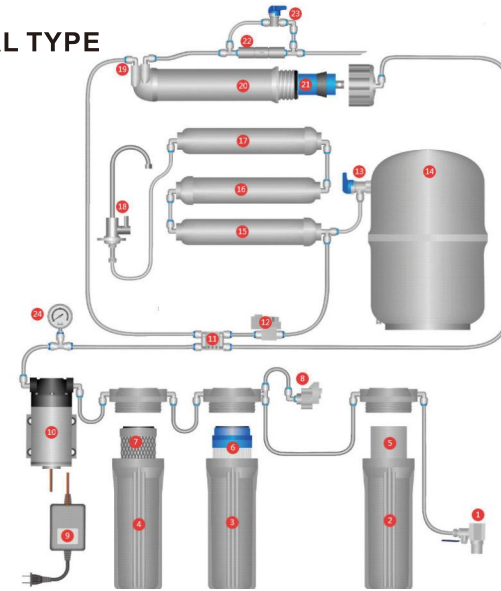

NO:	Product name	NO:	Product name
1	Inlet T and ball valve 1/4"or3/8"	13	Switch of water storage tank
2	First stage filter bottle	14	water storage tank
3	Secondary filter	15	Coconut carbon filter cartridge
4	Tertiary filtration	16	Mineral filter cartridge
5	PP filter cartridge	17	Alkaline filter cartridge
6	Granular activated carbon filter element	18	Water filter faucet
7	Compressed activated carbon filter	19	check valve
8	low pressure controller	20	Ro membrane housing
9	power adapter	21	Reverse osmosis filter element
10	booster pump	22	Drain water proportioner
11	four-way valve	23	Flush control valve
12	high pressure controller	24	Pressure gauge - Shows the working pressure

◆ 18S MODE

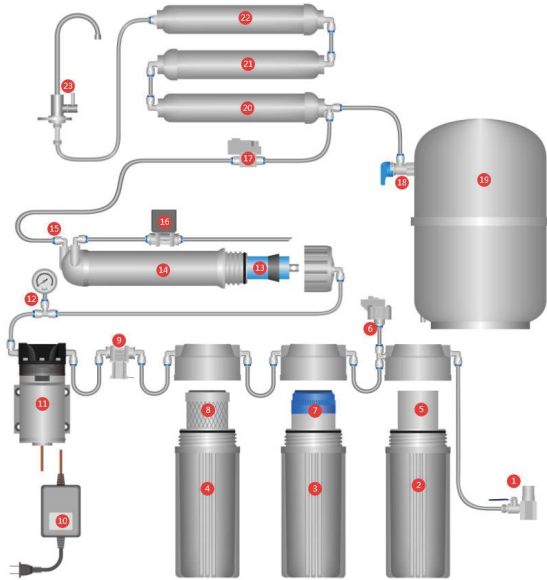

NO:	Product name	NO:	Product name
1	Inlet T and ball valve 1/4"or3/8"	13	Reverse osmosis filter element
2	First stage filter bottle	14	Ro membrane housing
3	Secondary filter	15	check valve
4	Tertiary filtration	16	Discharge water controller -18s
5	PP filter cartridge	17	high pressure controller
6	low pressure controller	18	Switch of water storage tank
7	Granular activated carbon filter element	19	water storage tank
8	Compressed activated carbon filter	20	Mineral filter cartridge
9	water inlet solenoid valve	21	Alkaline filter cartridge
10	power adapter	22	Water filter faucet
11	booster pump	23	Water filter faucet
12	Pressure gauge - Shows the working pressure		

◆ AUTOMATIC MODE

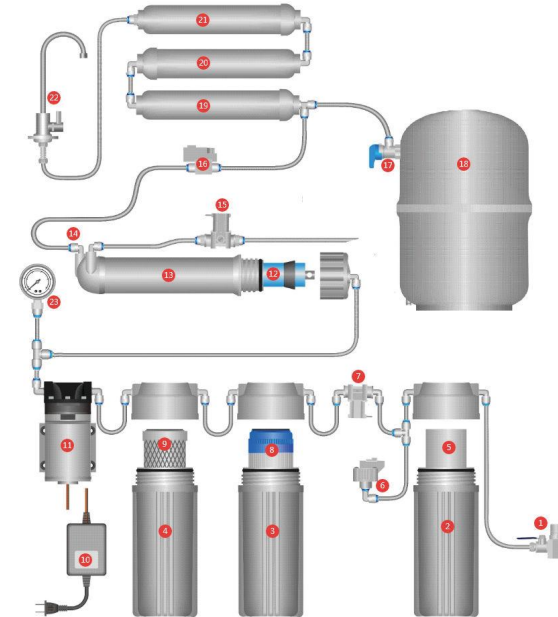

NO:	Product name	NO:	Product name
1	Inlet T and ball valve 1/4"or3/8"	13	Ro membrane housing
2	First stage filter bottle	14	check valve
3	Secondary filter	15	Discharge water controller
4	Tertiary filtration	16	high pressure controller
5	PP filter cartridge	17	Switch of water storage tank
6	low pressure controller	18	water storage tank
7	water inlet solenoid valve	19	Mineral filter cartridge
8	Granular activated carbon filter element	20	Alkaline filter cartridge
9	Compressed activated carbon filter	21	Water filter faucet
10	power adapter	22	Water filter faucet
11	booster pump	23	Pressure gauge - Shows the working pressure
12	Reverse osmosis filter element		

2.5 Circuit working principle

◆ MANULAL TYPE

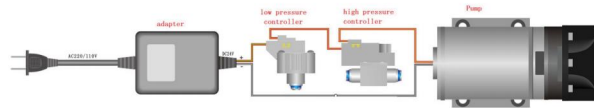

◆ 18S MODE

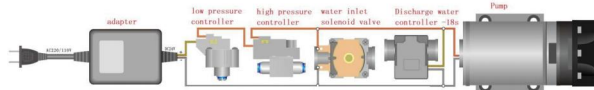

◆ AUTOMATIC MODE

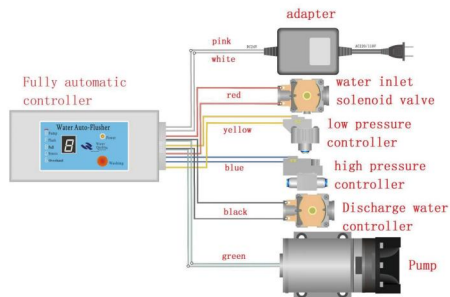

3. MAIN TECHNICAL PARAMETER

NO:	project name	parameters
1	Machine size (Hanging plate type)	39 (L) × 29 (W) × 57 (H) cm
2	Machine size (Bracket type)	38 (L) × 28 (W) × 76 (H) cm
3	Packing size (Hanging plate type)	36 (L) × 23 (W) × 42 (H) cm
4	Packing size (Bracket type)	36 (L) × 23 (W) × 46 (H) cm
5	Total gross weight :	11-15kgs (The weight varies depending on the configuration)
6	Input voltage:	AC100-240V/2.0A
7	Model size — electricity consumption	75GPD-25W 100GPD-50W 200GPD-70W 300GPD-80W 400GPD-100W
8	Model size — Net water flow (day)	75GPD-280L 100GPD-370L 200GPD-750L 300GPD-1100L 400GPD-1500L
9	water storage tank	3.2G≈6-7L (There are Other options)
10	Applying water pressure	0.1-0.35Mpa
11	Inlet water temperature	1-45°C
12	Water supply :	tap water or ground water TDS 1000ppm less
13	The type of gyard against electric shock	tyoell

4.INSTALLATION

4.1 The system installation method should be determined in accordance with the actuality of your kitchen. Please refer to the installation maps as follows. if the RO unit would be suspended on the wall ,it should be hammered two M5 swelling screws or twoconcrete steel nails according to the aperture on the RO unit hanger plate ,After installation, be sure to test the parts and joints for water leakage.

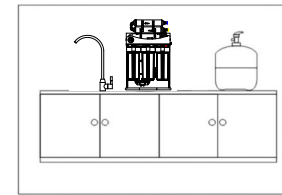

On the countertop

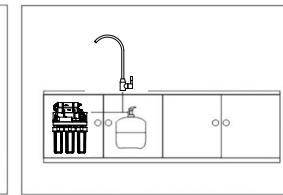

Under the countertop

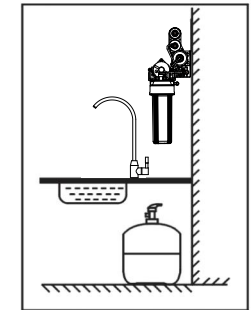

Mount on the wall

4.2 Connecting method of PE hose

Press the buckle to pull out the PE hose

PE pipe status before installation

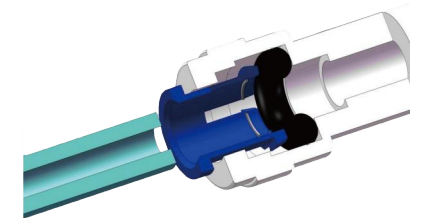
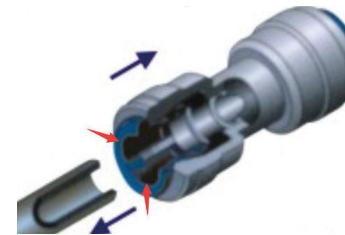

Status of PE pipes and connectors after installation

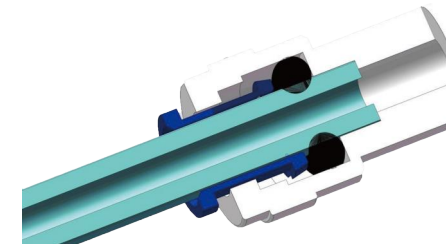

- 4.3 PE hose pipe cutting method:**
After calculating the appropriate length of PE hose, cut it flat



- 4.4 Installation of the first three filter elements:** unscrew the filter bottle, tear apart the packaging of the three filter elements, respectively put the three filter elements into the corresponding filter bottle, and then tighten the filter bottle, Note that the sealing ring in the filter bottle must be properly installed.

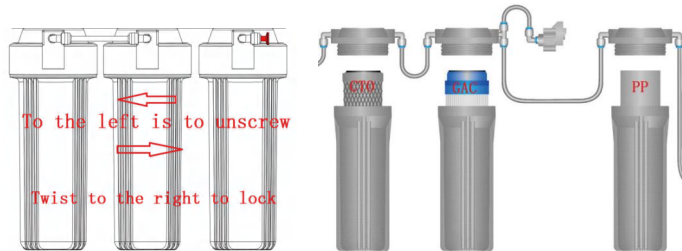

- 4.5 To install the RO membrane :** screw off the cap of RO housing, put one end with two sealing rings of RO membrane into RO housing ,screw on the cap tight.

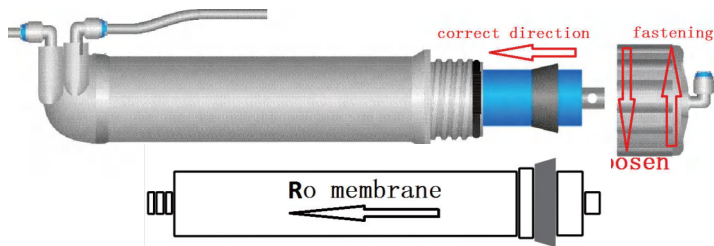

Installation between individual pipe components
General installation diagram of each component

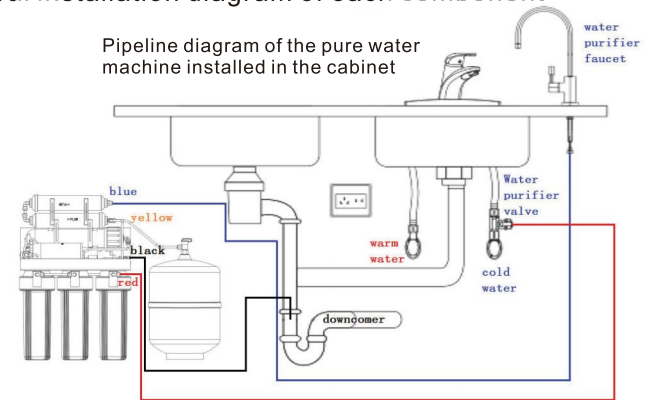

Hanging plate type

Diagram of port connection

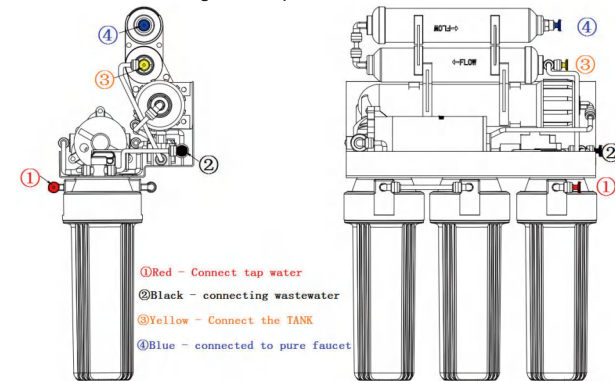

Bracket type

Diagram of port connection

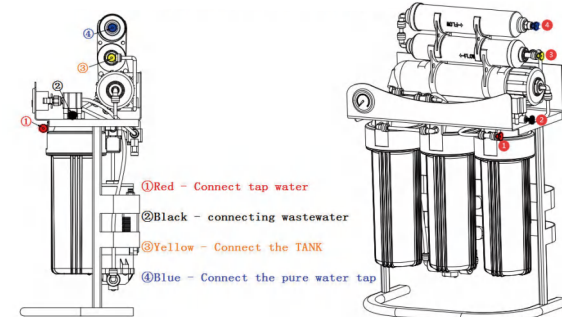

- ◆ Water purifier valve installation :
The inlet valve is installed in the middle of the triangle valve on the cold water pipe of the tap water, pay attention to the tightness, after installation, use PE to connect to the inlet of the first stage of the water purifier.

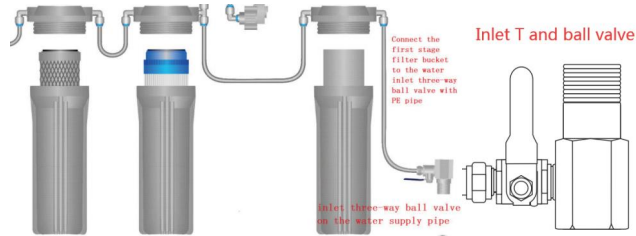

- ◆ The installation of pure water faucet:
The picture can be installed on the wall with the hanging piece, also can be installed on the kitchen counter (the faucet is installed behind the final filter element)

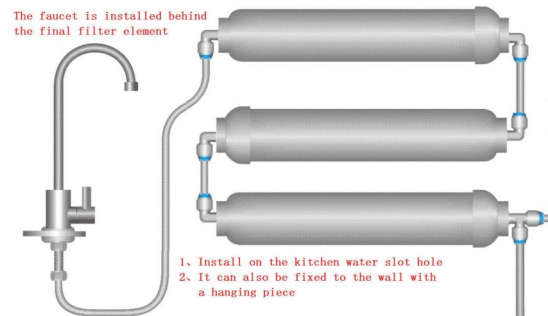
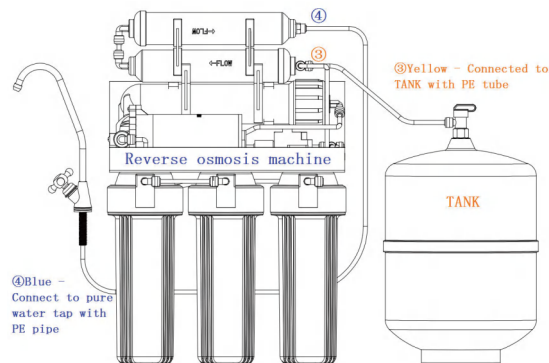

- ◆ Installation of water storage drum
Wrap about 12 rounds of sealing tape or sealant clockwise at the water nozzle of the water storage bucket, and then install the valve of the water storage bucket on the water nozzle of the water storage bucket;
Connect the water storage barrel to the No. 3 yellow mark on the pure water machine with a PE pipe, and detect whether there is leakage.

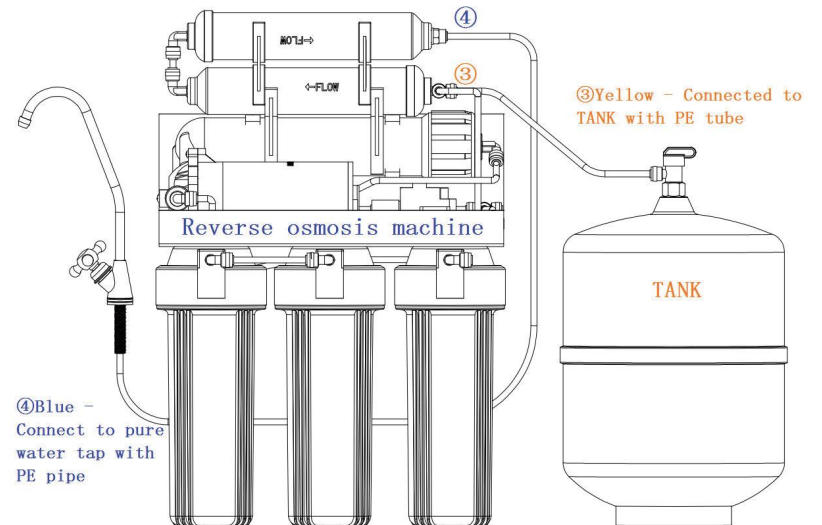

- ◆ Install and drain water: connect the PE pipe to the black port in the figure, and insert the other end of the PE pipe into the floor drain.

Pipeline diagram of the pure water machine installed in the cabinet

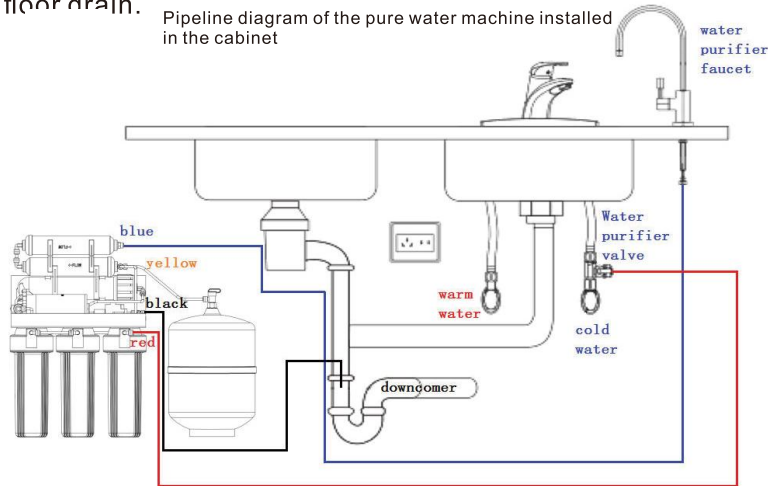

5. OPERATIONAL APPROACH

5.1 After the installation, The approach is as following :

- Open the tap water valve and supply water to the water purifier;
- turn off the tank valve of water storage tank ;
- Plug it in to power the water purifier ;
- The water purifier equipment starts to run ;
- The wastewater mouth began to discharge concentrated water:
- Manual machines need to manually open the drainage valve to discharge concentrated water, automatic machines will automatically enter the flushing state ;
- Flushing time according to the use of local water quality, about 10-30 minutes,the need for human operation ,Automatic machines need to press the flush button on the controller;
- After the washing is completed, turn off the washing switch, the automatic machine will turn off itself, and the equipment will enter the working state of filtered water in the next stage;

- Open the pure water faucet, see whether the water flow is normal after filtration, test whether the TDS value of the pure water machine meets the drinking standard, if not, continue to rinse;
- Close the pure water faucet, open the valve of the water storage bucket, and the filtered water enters the water storage bucket, which can be filled in about 30 minutes to 60 minutes ;
- When you use this system for the first time , let the purified water flow out from the full water storage tank two times , then the purified water can be suitable for drinking ;
- Check the water purifier itself, tap water valve, water storage tank valve, water purifier faucet, drain outlet and other places for leakage, if yes, cut off the water source and power supply and reinstall.

5.2 Matters need attention

When we use for the first time, black water will come out of the faucet, which is the broken carbon powder in the rear filter element, please discharge it before use;

When we use the system for the first time, TDS test data maybe a bit high ,please continue washing until the TDS test data reach the normal limitation :

When we use the system for the first time, the purified water can be drunk until the above steps are becoming normal. The concentrated waste water will be let out in the course of making purified water, It can be used for washing , but not for drinking After the installation & adjustment, the system can begin to make purified water automatically, Normally , turn off the goose-neck faucet, turn on the tank valve of water storage tank, let the purified water into tank ,when water storage tank is full of purified water ,the system will stop working automatically. Turn on the goose-neck faucet when you would like to use the purified water ,the water will flow out automatically.

6.MAINTENANCE

6.1 It is highly recommended to replace filters periodically to keep a high quality of water. This helps to take full advantage of filters and guarantee the water quality to reach its standard. If the user takes care of the filters and replaces periodically, the water purifier system could have optimization in lifetime. The period of filter-replacement depends on the quality of the raw water, the impurity quantity of the raw water. Based on empirical statistics, a family of four persons usually consumes 10L(10kgs) purified water everyday. If water is municipal tap water, the suggested period of replacement is shown as follows :

6.2 Brief introduction to filters:

Filter	Materials	Functions	Material life in average(depending on water quality and volume)
1 st Stage	PP 5 micron	Un-dissolved contaminants removal, i.e. sand, silt, rust, etc.	About 1-6 months
2 nd Stage	Activated carbon	Activated carbon germicidal adhesion removal of chlorine, organic fertilizer, agricultural chemical, insecticide	About 3-12 months
3 rd Stage	Block carbon	Same as 2nd stage, but re-filtration again	About 3-12 months
4 th Stage	RO membrane	Heavy metal removal: particles, heavy metal, ray, bacteria. etc.	About 1- 2 year
5 th Stage	Alkaline filter cartridge	Adjust the pH of the water	About 1- 2 year
6 th Stage	Mineral filter cartridge	Increase the mineral content of the water	About 1- 2 year
7 th Stage	In-line carbon	Adhere odor & taste and make water delicious	About 1 -2year

6.3 If filters are replaced in a good frequency , it could make sure that system generates the high quality and delicious drinkingwater and works normally. For difference conditions, above data of the period of the filters replacement is only for your reference.

6.4 RO membrane pressure washing :

When RO membrane purifies the water, there will be impurity and bacteria left on the surface of the water, which may affect the quality and volume of the purified water system more or less . Thus the RO membrane must be cleaned periodically . in our system, the RO system will flush the RO membrane automatically.

And you can also flush the RO membrane manually using the strong flushbutton on the RO controller box. Notice :In order to make you system work better, please use the specified filters which our company provides.

7.WARNING

- 7.1** Don't drink the water of first two tanks; let it flow out upon installation. And test the RO unit about 2 hours until the above operations pass completely :
Clean the remaining contaminants and sediment in the unit
Check if the unit works normally, without water leakage.
Make sure that the TDS value of purified water conforms to the standard quality of drinking water below 50ppm.
- 7.2** Don't take apart the parts of system. Any wrong operation may lead to water leakage and system failure/damage.
- 7.3** Don't apply the system to purify hot water.
- 7.4** In order to ensure the quality of clean water, please replace the first 3 stages of filter at most every 6 months.
- 7.5** Please check the power supply and make sure that it is applied with suitable voltage.
- 7.6** Keep the RO unit away from sunshine.
- 7.7** When the system will not be used for a long period, please turn off the power and shut off the ball valve.
- 7.8** Follow the initial operation before reusing the system after longtime idle.
- 7.9** Load、 move and install it carefully.

8. TROUBLE SHOOTING

If you encounter the several cases of problems, please check as follows:

- 8.1** Pump can not work to generate purified water:
- ◆ Check if the pressure of water supply is high enough to work. The RO controller box does not start the pump under low pressure.
 - ◆ Check if either high pressure switch or flush valve works could not jump back.
 - ◆ Check if the fuse on transformer is burned, if it does, then
 - ◆ Check if post in-line carbon filter (T33) or PP cartridges was stuffed, it may cause the pump to be overloaded
- 8.2** RO system does not operate.
- Check if power supply is normal.
Check if the feed water ball valve has been turned on (check if water pressure is normal).
Check if the water storage tank is full of water
- 8.3** RO system can not operate automatically
- Check if there is any wrong operation.
Check if the high and low pressure valve is normal.
- 8.4** Pump head leakage:
- Check if post in-line carbon filter (T33) or PP cartridges Stuffed cause the leaking. Sometime the leakage may caused by the increased pressure because of water in pump head cannot be delivered outward. if so, replace all the carbon cartridges and send the pump for repair.
Also either the weakened diaphragm or the stuffed scale would cause the leaking.
The water can not flow out due to the stuffed RO membrane, which is caused by the stuffed flow restrictor. Then the pump head is filled with high pressure water caused leaking. It could be recovered by improving there relevant components. (I do not know exactly what to express here)
- Pump is operating normally, but can not generate purified water: The cause may be RO membrane is stuffed or pump is out of pressure, If you can make sure that the cause is RO membrane being stuffed, please replace the RO membrane. If the cause is pump being out of pressure, please check if it is due to either the pump is being long time heavily loaded or the filtering materials is often stuffed and the adequate maintenance is not made, they caused the pump structure weakened. Send pump for repairing.

- 8.6** No purified water outletting while tank is full of water :
- ◆ The cause may be the air inside the tank is out. Please recharge the air (7 psi) and check if the tank has air leakage. If it does, please replace the tank.
 - ◆ If the post in-line carbon filter is stuffed. Please replace the filter.
- 8.7** The waste water keeps on discharging when the button of RO system setting is put at the stopped position.
- ◆ Check if flush valve is operating normally, otherwise, replace it.
 - ◆ The input water valve was damaged.
- 8.8** RO system could not be completely stopped or restart operating quickly while the tank is full.
- ◆ High pressure switch is out of work. Please repair or replace it.
 - ◆ Check valve is releasing pressure and not locked well. Please replace it.
- 8.9** The volume of purified water is too less :
- ◆ Check if the filters are too dirty and exceeded the filter's service life. If it is caused by the RO membrane is too dirty or not be flushed regularly. Please replace it.
 - ◆ Check if temperature of water is too low.
- The water delivering pressure is not as good as that of the new system. Please replace the pump.

9. PACKING LIST

Different machine packing list accessories will be different

Name	Quantity	Name	Quantity
Inlet T and ball valve 1/4 or 3/8"	1 pcs	Water filter faucet holder	1 pcs
Tank valve	1 pcs	Screws: 5×30mm	5 pcs
1/4 or 3/8" PE pipe	5 meter	Water housing spanner	1 pcs
Tank (3.2/4.0)	1 pcs	Ro membrane housing spanner	1 pcs
Ro membrane (75G-400G)	1 pcs	Sealing ring of 3 filter housing	3-6 PCS
Water filter faucet	1 pcs	PP+GAC+CTO bottle label	3 piece
quick connector for water filter faucet	1 pcs	Down pipe clamp	1 pcs
Product specification	1 this	Teflon tape	1 pcs